

PRECISION SAWMILL CHIP SCREEN



Precision "Fixed-Rotary" Chip Screens incorporate proven engineering features to assure long-life performance with consistent high quality production. The smooth glide of the fixed rotary counter weight from the balanced center axis of the drive unit, provides year after year of high performance with a minimum of maintenance. The low profile receiving pan is additional assurance that your Precision "Fixed-Rotary" Chip Screens will meet the most demanding requirements of any chip specifications.

◀ *Chip Screens are suspended from frame, with 1/4" stress proof hanger rods with rod end bearings.*

Hanger rods are available with universal joints as an option. ▶



Engineered for Performance – Built for Endurance

SAWMILL CHIP SCREENS



▲ *Standard Drive Arrangement*



Optional Bottom Belt Arrangement. Screen legs must be extended 12" to allow changing space. Simple belt change: remove belt guard, loosen motor take-up and replace belts.

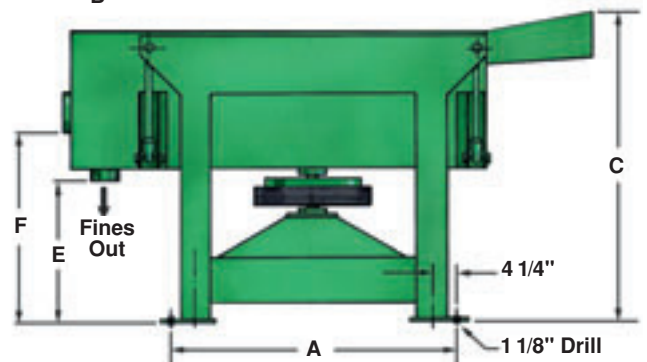
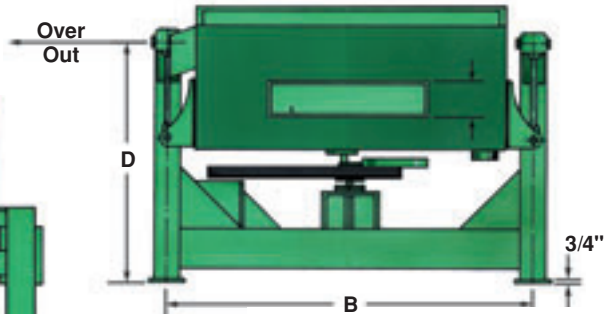
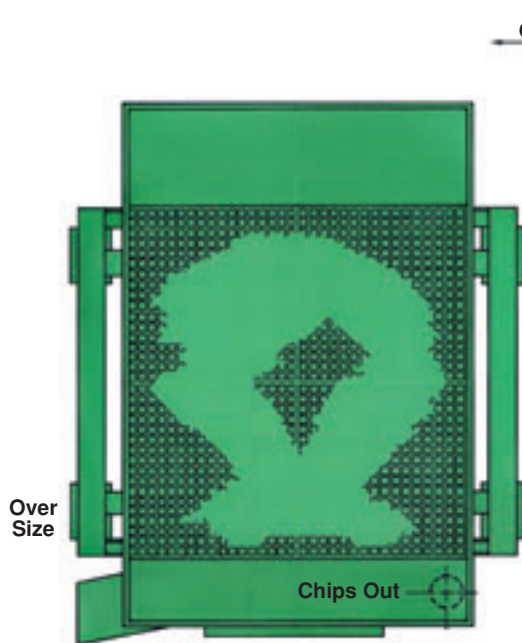

| DIMENSIONS | | | | | | INCHES |
|------------|------|-----|-----|-----|-----|--------|
| MODEL NO. | A | B | C* | D | E | F |
| PCS-55 | 49½ | 71 | 54 | 38 | 24½ | 32¾ |
| PCS-66 | 61½ | 83 | 54 | 38 | 24½ | 32¾ |
| PCS-77 | 73½ | 95 | 57⅝ | 41⅝ | 28 | 36⅝ |
| PCS-88 | 84½ | 109 | 70 | 49⅝ | 30⅝ | 37⅝ |
| *PCS-1010 | 109½ | 133 | 70 | 47¼ | 31⅝ | 38⅝ |

* This screen has six (6) legs and requires a special foundation.

| SPECIFICATIONS | | | | |
|----------------|----------------------|---------------------------------|------------|---------------------------|
| MODEL No. | *CAPACITY (TONS/HR.) | SCREEN SURFACE (SIZE IN INCHES) | H.P. REQD. | APPROXIMATE WEIGHT (LBS.) |
| PCS-55 | 13 | 60 x 60 | 2 | 2736 |
| PCS-66 | 18 | 72 x 72 | 3 | 3258 |
| PCS-77 | 25 | 84 x 84 | 5 | 4100 |
| PCS-88 | 40 | 96 x 96 | 7½ | 6500 |
| PCS-1010 | 65 | 120 x 120 | 10 | 8437 |

* Based on full size discharge opening.

**ENGINEERS AND MANUFACTURERS OF
WORLD CLASS EQUIPMENT FOR CHIPMILLS,
SAWMILLS, WOOD YARDS, LOG LOADING AND
IN WOODS DEBARKING/CHIPPING AND
WOOD WASTE GRINDING.**

Quality Driven - Service Oriented



P.O. DRAWER 507 • LEEDS, AL 35094-0507 • 205/640-5181 • FAX 205/640-1147
EMAIL: sales@precisionhusky.com • WEB SITE: www.precisionhusky.com